

PGA-EG

Governor/Actuator for marine applications

APPLICATIONS

The Woodward PGA-EG Governor/Actuator is designed specifically for marine applications requiring electronic engine control with mechanical backup. The governor/actuator combines the proven dependability of the hydro-mechanical PG governor with the flexibility of an electronic control.

The mechanical governor features pneumatic tracking of the speed setting, which gives complete backup speed control from a remote location, with only a slight change in engine speed should the electronic signal fail.

The PGA-EG can be used with a variety of Woodward electronic controls. The backup hydro-mechanical governor gives it redundant speed control for critical marine needs.

Outputs from 16 to 678 N·m (12 to 500 lb-ft) allow use on all sizes of marine engines.

The actuator portion of the PGA-EG requires a 0–200 mA control signal. This is compatible with all Woodward electronic controls.

DESCRIPTION

Backup speed control is accomplished by the simultaneous operation of hydro-mechanical (PGA) and electronic (EG) governing systems. To achieve backup control, the electronic system must be reverse-acting (an increase in fuel is called for by a reduction in current to the actuator portion of the PGA-EG).

Setting the speed of the mechanical governor slightly higher than that of the electronic governing system causes the mechanical portion of the PGA-EG to

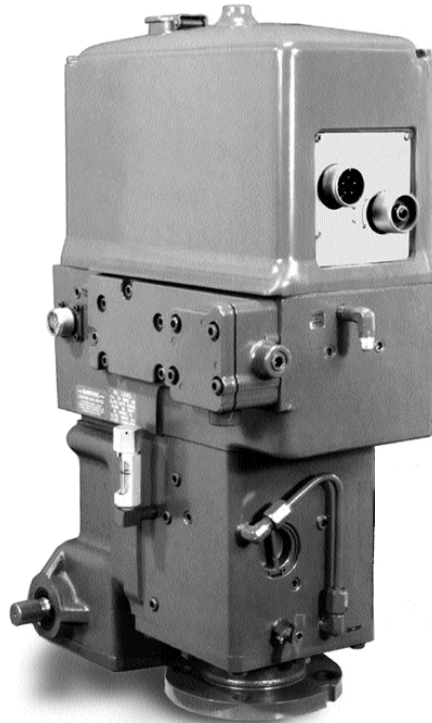

always seek a fuel setting higher than that being controlled by the electrical part of the PGA-EG. Electrical control thus controls the fuel position because of the least-fuel-selection feature.

Should the electronic signal to the PGA-EG drop to 0, due to some problem in the system, the electric actuator will call for an increased fuel position above the setting of the mechanical governor. At this point, the mechanical speed setting is lower and the ballhead controls the engine-fuel setting.

Although the speed will be slightly higher under mechanical control, no gross overspeed or shutdown occurs due to a loss in signal from the electronic control.

Direct-acting PGA-EG controls are available. These units will go to minimum fuel on loss of electronic control signal.

- Compatible with all Woodward analog or digital electronic controls
- Pneumatic signal sets mechanical governor speed
- All PG drives, outputs available
- Vibration-resistant construction
- Designed to meet SOLAS (Safety of Life at Sea) requirements

SPECIAL FEATURES

Tracking Electronic Fuel Setting

The system requires the user to provide two simultaneous speed-setting signals (current and pressure). Because simultaneous speed-setting signals are provided to both portions of the PGA-EG, speed increases only slightly during transition, regardless of what speed is at the time of the transfer.

The standard PG adjustable needle valve and buffer compensation system is included in the mechanical side of the PG-EG to adjust for stability of individual engines.

Speed, droop, shutdown devices, and torsional-resistant ballheads are available for the mechanical portion of the PGA-EG.

Linear or Rotary Outputs

Constructed on the standard Woodward PG power case, the PGA-EG is available with all PG linear or rotary output configurations.

Base and Drive Connections

All current PG governor bases can be used with the PGA-EG. The PGA-EG will adapt to most marine engines being built today and is also available for retrofit to most existing marine propulsion systems, in many cases without changes in linkage, drive, or other configurations.

Hydraulic Circuits

The PGA-EG operates from its own sump, using the high volume PG oil pump and accumulators. The proven PG pump and accumulator is reversible or may be set for one-way rotation. A 140 µm, wire-mesh filter is accessible from the outside of the PGA-EG case. The filter protects the small orifice in the pilot valve, which is an integral part of the electric actuator.

OPTIONAL FEATURES

Mode Select Valve

A mode selector is available which allows a manual, electric, or pneumatic signal to remove the electronic

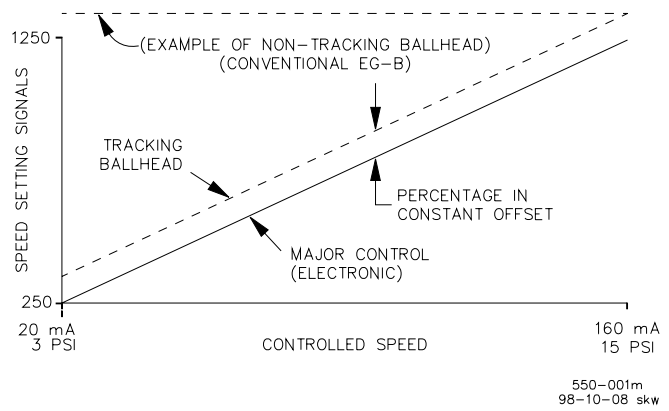

Tracking Ballhead Concept

control from the system for start-up without power and other conditions where mechanical-governor control is desirable.

Booster Servomotor

A booster servomotor may be used with the PGA-EG to help the prime mover start quickly by moving the actuator output toward the maximum-fuel position at start-up.

Governor Heat Exchanger

A remote heat exchanger may be required to lower governor oil temperatures in applications where governor oil tends to exceed 93 °C (200 °F).

LVDT Precise Position Feedback

Precise, closed-loop electronic limiting can be accomplished with optional LVDT fuel-position feedback.

Mode Indication Switch

A switch is available which has both normally open and normally closed contacts. The state of the switch indicates whether the engine is under electronic or mechanical control.

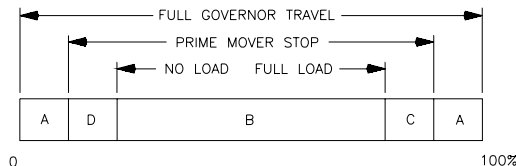
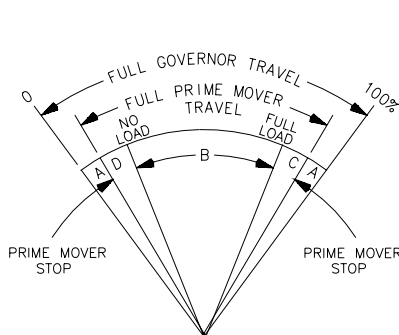

- A - OVERTRAVEL TO INSURE PRIME MOVER STOPS ARE REACHED.
- B - NO LOAD TO FULL LOAD TRAVEL - NORMALLY 2/3 OF FULL GOVERNOR TRAVEL IS RECOMMENDED.
- C - TRAVEL REQUIRED TO ACCELERATE THE PRIME MOVER.
- D - TRAVEL REQUIRED TO DECELERATE OR SHUT DOWN PRIME MOVER.

M-155a
98-04-14 skw

MAXIMUM WORK CAPACITY OVER FULL GOVERNOR TRAVEL OF 42° IS * . SEE ABOVE FOR RECOMMENDED GOVERNOR OUTPUT TRAVEL. IN SPECIAL APPLICATIONS MIN AND MAX PRIME MOVER STOPS MAY BE OUTSIDE THE GOVERNOR STOPS.

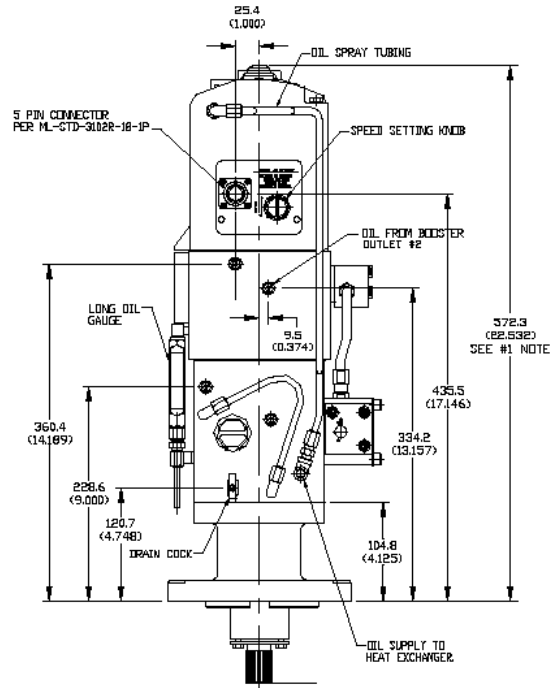
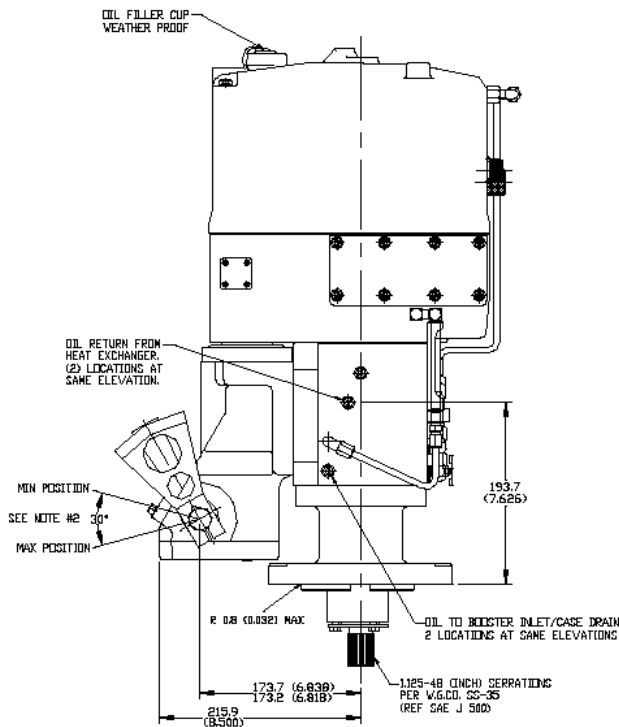

NOTES:

- 1 6930 CLEARANCE FROM MOUNTING SURFACE REQUIRED TO REMOVE COVER.
- 2 30° STROKE AVAILABLE. RECOMMENDED TRAVEL BETWEEN NO LOAD AND FULL LOAD IS 20°.
- 3 B576-894 OPERATES AT 850 PSIG. THIS INCREASING ROTARY SERVO RATING TO 75 FT-LBS.
- 4 ALL BOOSTER, DRAIN AND HEAT EXCHANGER CONNECTIONS HAVE 1/25-27(INCH) NPTF THREADS.

METRIC

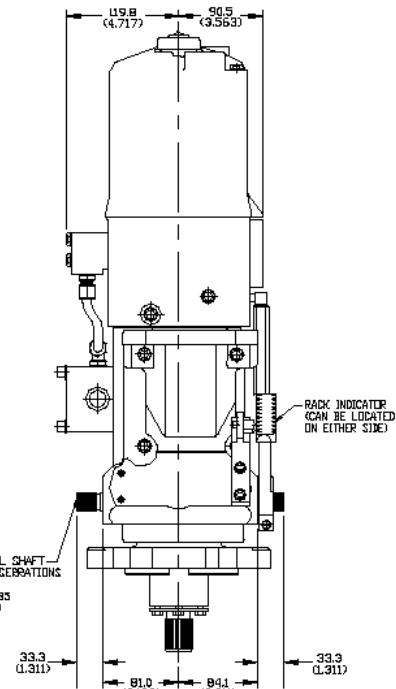
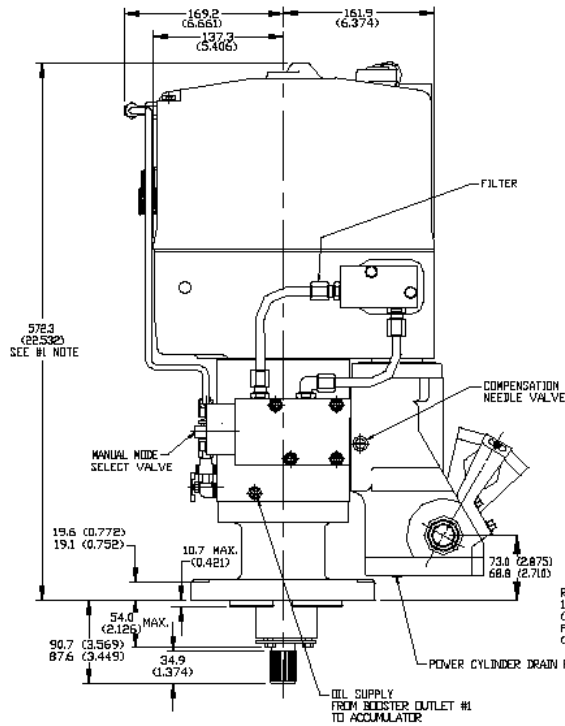
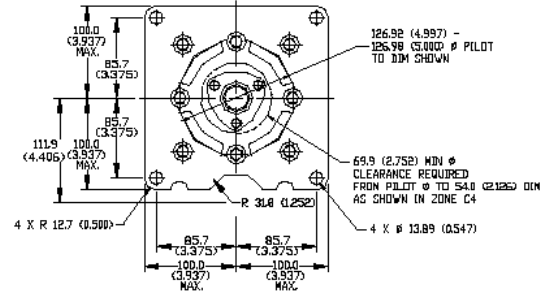

Outline Drawing of PGA-EG 200
(Do not use for construction)

PO Box 1519
 Fort Collins CO, USA
 80522-1519
 1000 East Drake Road
 Fort Collins CO 80525
 Ph: +1 (970) 482-5811
 Fax: +1 (970) 498-3058

Distributors & Service
 Woodward has an international network of distributors and service facilities. For your nearest representative, call the Fort Collins plant or see the Worldwide Directory on our website.

Corporate Headquarters
 Rockford IL, USA
 Ph: +1 (815) 877-7441

www.woodward.com

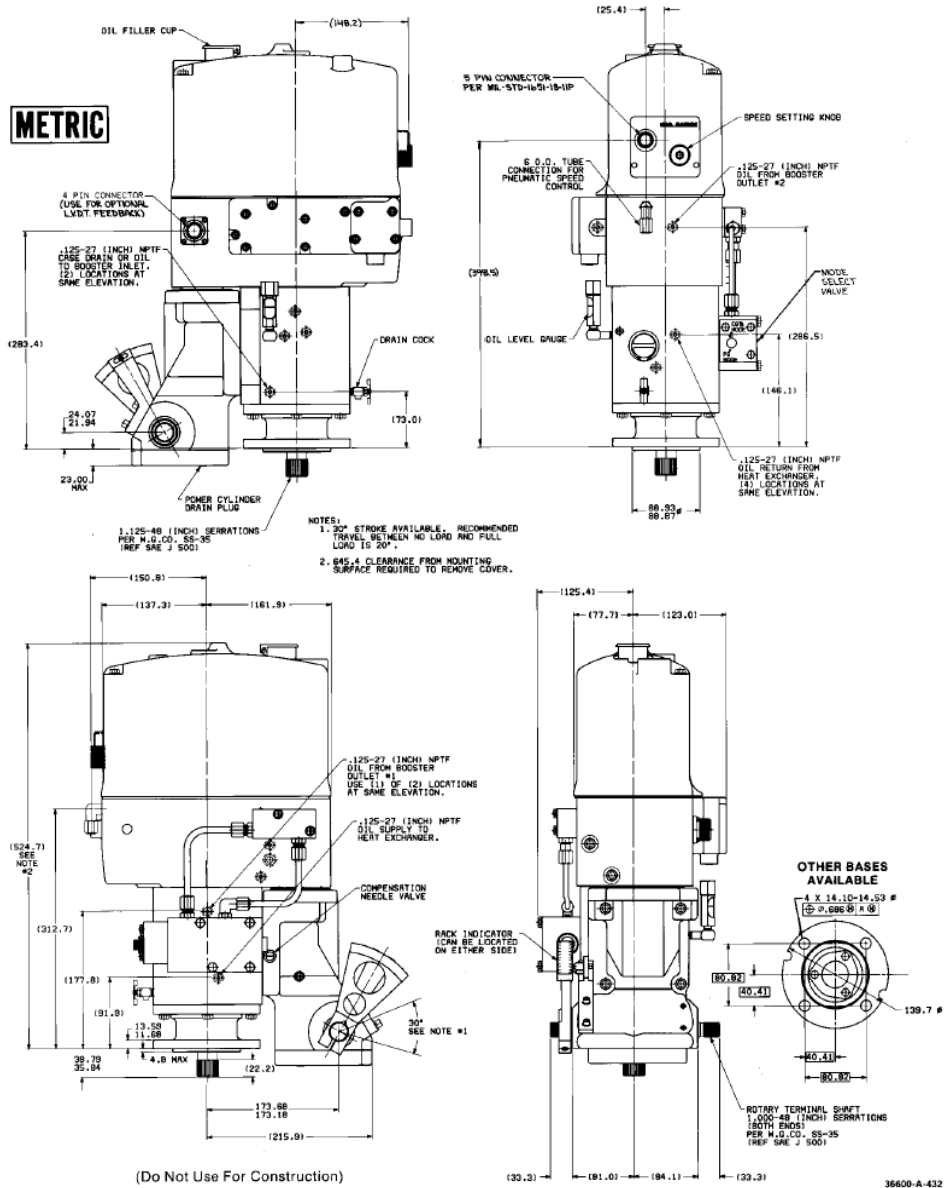

Outline Drawing of PGA-EG 29/58
 (Do not use for construction)

This document is distributed for informational purposes only. It is not to be construed as creating or becoming part of any Woodward Governor Company contractual or warranty obligation unless expressly stated in a written sales contract.

© Woodward 1986
 All Rights Reserved

04/7/F

For more information contact: